

Precise and reliable measurement,
optimization and management.



YAGEO Nexensos

Sensors for the efficient and responsible
use of resources.

YAGEO Nexensos

Precise, reliable, and optimized measurement



Sustainability, environmental awareness and energy efficiency are worldwide concerns, and important drivers for future development. Key technologies for clean air, energy efficiency and conservation of resources are both a responsibility and a challenge.

High precision temperature measurement is essential for these technologies and, in addition to accuracy, stability and reliability are important prerequisites for successful technical solutions, and their efficient use.

Platinum thin-film technology offers outstanding advantages in a wide variety of applications, and is the first choice when it comes to accuracy and long-term stability.

As a specialist in high-precision temperature measurement, YAGEO Nexensos, with more than 100 years of experience, is the global market leader in thin-film platinum sensor technology.

With our portfolio of sensors, capable of performing highly accurate measurements over the temperature range of -196°C to $+1000^{\circ}\text{C}$ in gases, liquids and solids, we provide advanced standard and customized solutions.

The most important application areas include the automotive, household appliance, process technology, energy production and energy management, electronics and life science fields. Our solutions help protect the environment, promote the efficient use of energy, facilitate precision analysis, and help to maximize safety in these fields.

In this brochure for you:

A partner for your goals	Page 4
Solutions for key technologies	Page 5
Technical principles	Page 6
Sensor Elements with wire leads	Page 10
Platinum Sensors for electronic circuits	Page 25
Sensor Elements on a PCB	Page 34
Solutions and Sensor Modules for customized applications	Page 38

YAGEO Nexensos

A partner for your goals



Innovation as a matter of principle

Our customers are invited to utilize our innovative technology and vast experience in the field of platinum thin-film technology. As a development partner and solutions provider, in close cooperation with our customers, we continually create innovative products and applications with impressive performance and efficiency. Our track record? Millions of sensors, operating world-wide, every day.

Technology with vision

As pioneers in industrial precious metal processing, and specialists in platinum-based temperature measurement, you can count on YAGEO Nexensos for extensive expertise, technological experience and a nearly unlimited bandwidth of possible applications. We help ensure that your large-scale production is fast and stable, with continuous improvement always in mind.



Quality and responsibility

The million-fold mass production of high-precision sensors requires comprehensive quality assurance. To insure that our customer's strictest quality requirements are met, the ISO/TS 16949 automotive quality management system is followed. In addition, extensive methods relating to anticipatory quality planning are used.

For quality with a future, look for Made in Germany.

YAGEO Nexensos

Advanced solutions for the key technologies of today and tomorrow

Automotive:

- Designed and produced with direct customer dialog
- Constant product optimization based on customers' needs
- Compliance with statutory emissions requirements
- Reduction of fuel consumption
- Increased vehicle operational safety thanks to precise sensor technology operating up to +1050 °C
- Extended component service life



Household appliances:

- Individually customized sensor solutions
- High quality final products
- Extremely reliable and durable Pt sensor technology
- Cost-effective high volume production

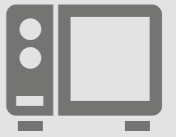

Process technology:

- Dependable process management
- Reduction of maintenance costs and downtime
- Cost-effective standard products in Pt thin-film technology
- High-precision sensors for specialized customer requirements



Energy production and energy management

- Temperature monitoring for alternative and conventional energy production
- Heat management and energy conservation
- Application-specific, cost-optimized solutions
- Cost savings achieved via simple mounting capability
- Cost-effective products mass-produced in Pt thin-film technology

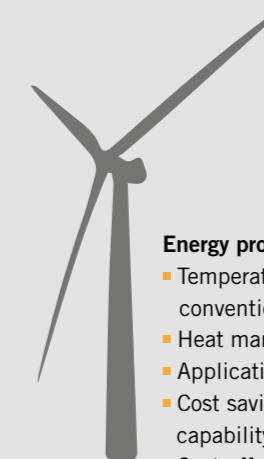

Electronics:

- Precise temperature measurement
- Automated assembly
- Compensation for component thermal drift effects
- High-volume production at low-cost
- Standardized characteristic curve DIN EN 60751
- AECQ 200 certified products

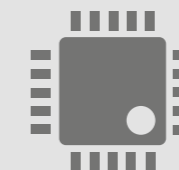

Life science:

- Biocompatibility
- Heater-sensor combinations and multi-sensor platforms for customer-specific applications
- Ramp-up capability for large-scale production



Platinum Temperature Sensors in Operation

Technical principles

The change in electrical resistance of a platinum sensing element is precisely defined by the temperature; as a result, this relationship can be utilized for thermometry. The relationship is listed in the table of basic values for Pt 100 (TC = 3850 ppm/K).

Some of the parameters that influence platinum thin-film sensors over their service life are as follows:

Measurement currents and self-heating

The supply current heats the platinum thin-film sensor. The resulting temperature measuring error is defined by: $\Delta T = P \cdot S$ where P, the power loss = $I^2 R$ and S, the self-heating coefficient in K/mW.

The self-heating coefficients are specified in the data sheets for the individual products. Self-heating is dependent on thermal contact between the platinum thin-film sensor and the surrounding medium. If the heat transfer to the environment is efficient, higher measurement currents can be used. Platinum thin-film sensors have no low limits for measurement current. The optimal measurement current is greatly dependent upon the specific parameters of the application.

General recommendations for test current:

100 Ω :	0.3 to max. 1.0 mA
500 Ω :	0.1 to max. 0.7 mA
1000 Ω :	0.1 to max. 0.3 mA
2000 Ω :	0.1 to max. 0.3 mA
10000 Ω :	0.1 to max. 0.25 mA

Basic values for 100 Ω platinum temperature sensors as per DIN EN 60751 (TS90) TC = 3850 ppm/K

$^{\circ}\text{C}$	Ω	$\Omega/^{\circ}\text{C}$	$^{\circ}\text{C}$	Ω	$\Omega/^{\circ}\text{C}$	$^{\circ}\text{C}$	Ω	$\Omega/^{\circ}\text{C}$	$^{\circ}\text{C}$	Ω	$\Omega/^{\circ}\text{C}$
-200	18.52	0.432	+70	127.08	0.383	+340	226.21	0.352	+610	316.92	0.320
-190	22.83	0.429	+80	130.90	0.382	+350	229.72	0.350	+620	320.12	0.319
-180	27.10	0.425	+90	134.71	0.380	+360	233.21	0.349	+630	323.30	0.318
-170	31.34	0.422	+100	138.51	0.379	+370	236.70	0.348	+640	326.48	0.317
-160	35.34	0.419	+110	142.29	0.378	+380	240.18	0.347	+650	329.64	0.316
-150	39.72	0.417	+120	146.07	0.377	+390	243.64	0.346	+660	332.79	0.315
-140	43.88	0.414	+130	149.83	0.376	+400	247.09	0.345	+670	335.93	0.313
-130	48.00	0.412	+140	153.58	0.375	+410	250.53	0.343	+680	339.06	0.312
-120	52.11	0.409	+150	157.33	0.374	+420	253.96	0.342	+690	342.18	0.311
-110	56.19	0.407	+160	161.05	0.372	+430	257.38	0.341	+700	345.28	0.310
-100	60.26	0.405	+170	164.77	0.371	+440	260.78	0.340	+710	348.38	0.309
-90	64.30	0.403	+180	168.48	0.370	+450	264.18	0.339	+720	351.46	0.308
-80	68.33	0.402	+190	172.17	0.369	+460	267.56	0.338	+730	354.53	0.307
-70	72.33	0.400	+200	175.86	0.368	+470	270.93	0.337	+740	357.59	0.305
-60	76.33	0.399	+210	179.53	0.367	+480	274.29	0.335	+750	360.64	0.304
-50	80.31	0.397	+220	183.19	0.365	+490	277.64	0.334	+760	363.67	0.303
-40	84.27	0.396	+230	186.84	0.364	+500	280.98	0.333	+770	366.70	0.302
-30	88.22	0.394	+240	190.47	0.363	+510	284.30	0.332	+780	369.71	0.301
-20	92.16	0.393	+250	194.10	0.362	+520	287.62	0.331	+790	372.71	0.300
-10	96.09	0.392	+260	197.71	0.361	+530	290.92	0.330	+800	375.70	0.298
0	100.00	0.391	+270	201.31	0.360	+540	294.21	0.328	+810	378.68	0.297
+10	103.90	0.390	+280	204.90	0.358	+550	297.49	0.327	+820	381.65	0.296
+20	107.79	0.389	+290	208.48	0.357	+560	300.75	0.326	+830	384.60	0.295
+30	111.67	0.387	+300	212.05	0.356	+570	304.01	0.325	+840	387.55	0.294
+40	115.54	0.386	+310	215.61	0.355	+580	307.25	0.324	+850	390.48	0.293
+50	119.40	0.385	+320	219.15	0.354	+590	310.49	0.323	-	-	-
+60	123.24	0.384	+330	222.68	0.353	+600	313.71	0.322	-	-	-

For additional tables for 500 Ω and 1000 Ω elements, please visit www.yageo-nexensos.com

Accuracy tolerance classification

YAGEO Nexensos supplies platinum thin-film sensors in accordance with DIN EN 60751 in the accuracy tolerance classifications F 0.60, F 0.30, F 0.15 and F 0.10 (see table below for limit variations for 100 Ω platinum sensors). Proportionally limited tolerances are based on:

Tolerance classification

Tolerance according to DIN EN 60751 2009-05	Tolerance according to DIN EN 60751 1996-07	Temperature range
F 0.10	Classe 1/3 B	0 $^{\circ}\text{C}$ to +150 $^{\circ}$
F 0.15	Classe A	-50 $^{\circ}\text{C}$ to +300 $^{\circ}\text{C}$
F 0.30	Classe B	-70 $^{\circ}\text{C}$ to +500 $^{\circ}\text{C}$
F 0.60	Classe 2B	-70 $^{\circ}\text{C}$ to +500 $^{\circ}\text{C}$

Platinum thin-film sensors can also be selected in tolerance groups with a maximum $\Delta T = 0.1$ K over a range of 0 $^{\circ}\text{C}$ to +100 $^{\circ}\text{C}$. For applications with high price sensitivity, other accuracy tolerances are also available.

Limit variations for 100 Ω platinum sensors

Temp. $^{\circ}\text{C}$	Limit variations			
	Class F 0.15		Class F 0.3	
	$^{\circ}\text{C}$	Ω	$^{\circ}\text{C}$	Ω
-200	± 0.55	± 0.24	± 1.3	± 0.56
-100	± 0.35	± 0.14	± 0.8	± 0.32
0	± 0.15	± 0.06	± 0.3	± 0.12
+100	± 0.35	± 0.13	± 0.8	± 0.30
+200	± 0.55	± 0.20	± 1.3	± 0.48
+300	± 0.75	± 0.27	± 1.8	± 0.64
+400	± 0.95	± 0.33	± 2.3	± 0.79
+500	± 1.15	± 0.38	± 2.8	± 0.93
+600	± 1.35	± 0.43	± 3.3	± 1.06
+650	± 1.45	± 0.46	± 3.6	± 1.13
+700	-	-	± 3.8	± 1.17
+800	-	-	± 4.3	± 1.28
+850	-	-	± 4.6	± 1.34

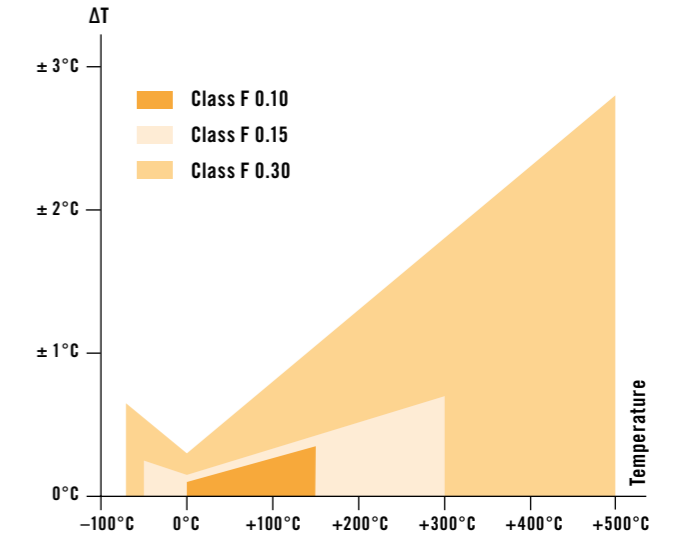

Tolerances of base values for Pt temperature sensors are specified in DIN EN 60751.

Thermal response times

The thermal response time is the time required by a platinum thin-film sensor to react to a step change in temperature. The response time value is specified for a particular percentage of the temperature change. DIN EN 60751 recommends that response time values be specified for 50% and 90% of the step change. $t_{0.5}$ and $t_{0.9}$ for water and air flows of 0.4 or 2.0 meters/second are indicated on the data sheets. Conversion to other media and speeds can be carried out with the aid of the VDI/VDE 3522 manual.

Thermo-electric effect

Platinum thin-film sensors generate virtually no electro-motive power.

Vibration and impact

Platinum thin-film sensors are solid-state components and are extremely resistant to vibration and impact. The qualifying factor is normally the mounting method. The testing of well mounted platinum thin-film sensors has confirmed typical performance as follows:

Vibration resistance: 40g over a range from 10Hz to 2kHz
Shock resistance: 100g, 8ms half sine

Platinum Temperature Sensors in Operation

Technical principles

General electrical parameters of the sensor elements

Inductance:	< 1µH
Capacitance:	1 to 6 pF
Insulation resistance:	>100 MΩ at +20°C >2 MΩ at +500°C
High-voltage strength:	>1000 V at +20°C >25 V at +500°C

Mechanical load capability

Platinum thin-film sensors are sensitive to mechanical loads that may, under extreme conditions, lead to a rupture or chipping of the glass cover or the ceramic substrate. Improper handling or unsuitable mounting processes may lead to permanent changes to the measurement signal.

During manufacture, the connection wires are subjected to pull and tear tests for quality assurance purposes

Repeatability

YAGEO Nexensos platinum thin-film sensors are characterized by a high degree of signal repeatability.

Long-term stability

The aging effects on temperature sensors as a result of long-term operation or temperature shock may have a negative influence on the precision and reproducibility of the sensor signal. Long-term stability is therefore of the greatest importance.

Platinum thin-film sensors are the most stable thin-film sensors available due to the chemical stability and homogeneity of platinum. Depending upon operating conditions, the resistance changes after 5 years of operation at +200°C are typically less than 0.04%. The standard test conditions include exposure times of 250, 500, and 1000 hours. Additional long-term tests, and shock tests, adapted to the customer's needs, are also available.

Climate and humidity

A double glass layer and glass-ceramic fixing drop reliably protect the sensor element from environmental influences. Measurements show that climatic and humidity variations do not have an impact on the measurement accuracy of sensor elements.

Circuit design

Platinum thin-film sensors are typically operated with a continuous current. For energy conservation reasons (accumulator or battery operation, for example), a switched measuring current may also be used. The voltage output signal is a function of the R_t resistance ($V=IR$). The simple quadratic function of the platinum thin-film sensor characteristic curve and the feasibility of a simple linear approximation allows for easy linearisation of the measurement signal.

Connection

Standard 2-lead circuits may result in a loss of accuracy. Therefore, 3 or 4-lead circuits are recommended:

- When longer extension cables are used, especially if significant resistance (including temperature dependent resistance) is added by the cable
- When platinum thin-film sensors with narrower tolerances are used
- When significant electromagnetic interference is present

Storage

Platinum thin-film sensors must not be exposed to caustic or corrosive conditions. The storage information specified for each type should be followed.

Cleaning

Platinum thin-film sensors are cleaned before packing and further cleaning is normally not required. Should cleaning be required after mounting, most conventional industrial processes can be used, including immersion in a liquid bath. We recommend the use of residue-free cleaning agents.

Handling

Platinum thin-film sensors are precision components, and should be handled carefully during mounting. Metal holders, clamps or other rough gripping devices should not be used. Plastic tweezers are recommended for working with sensor elements. The supply leads should not be bent near the body of the platinum thin-film sensor. Frequent repositioning of the supply leads should be also avoided.

Connection technology

The best results are achieved with welding processes (resistance welding, laser welding etc.) or soldering (soft, hard solder). When using hard solder, the platinum thin-film sensor body must not be heated above the maximum nominal temperature rating for the element. In general, to avoid damage, the soldering time for hard solder should be less than three seconds. Crimping and ultrasonic sealing is also possible.

- When crimping, steps should be taken to avoid high contact resistance at the junction.
- With ultrasonic sealing, the leads must be bent out of the plane of the platinum thin-film sensor in order to prevent interior damage.
- For the SMD and TO92 series, processing via wave or reflow soldering processes is recommended.

Adhesion and embedding

When bonding, embedding, powder encapsulating or coating platinum thin-film sensors, it is important to coordinate the thermal expansion coefficients of the different materials that are used to avoid mechanical stress that may affect the sensor signal.

The embedding materials should be chemically neutral. The position of a connected platinum thin-film sensor should under no circumstances be subsequently corrected by sliding its body. YAGEO Nexensos's MR series is already recast in a ceramic casing. The TO92 series is cast in plastic.

All standard sensors in this catalog are RoHS and REACH compliant, according to current legislation.

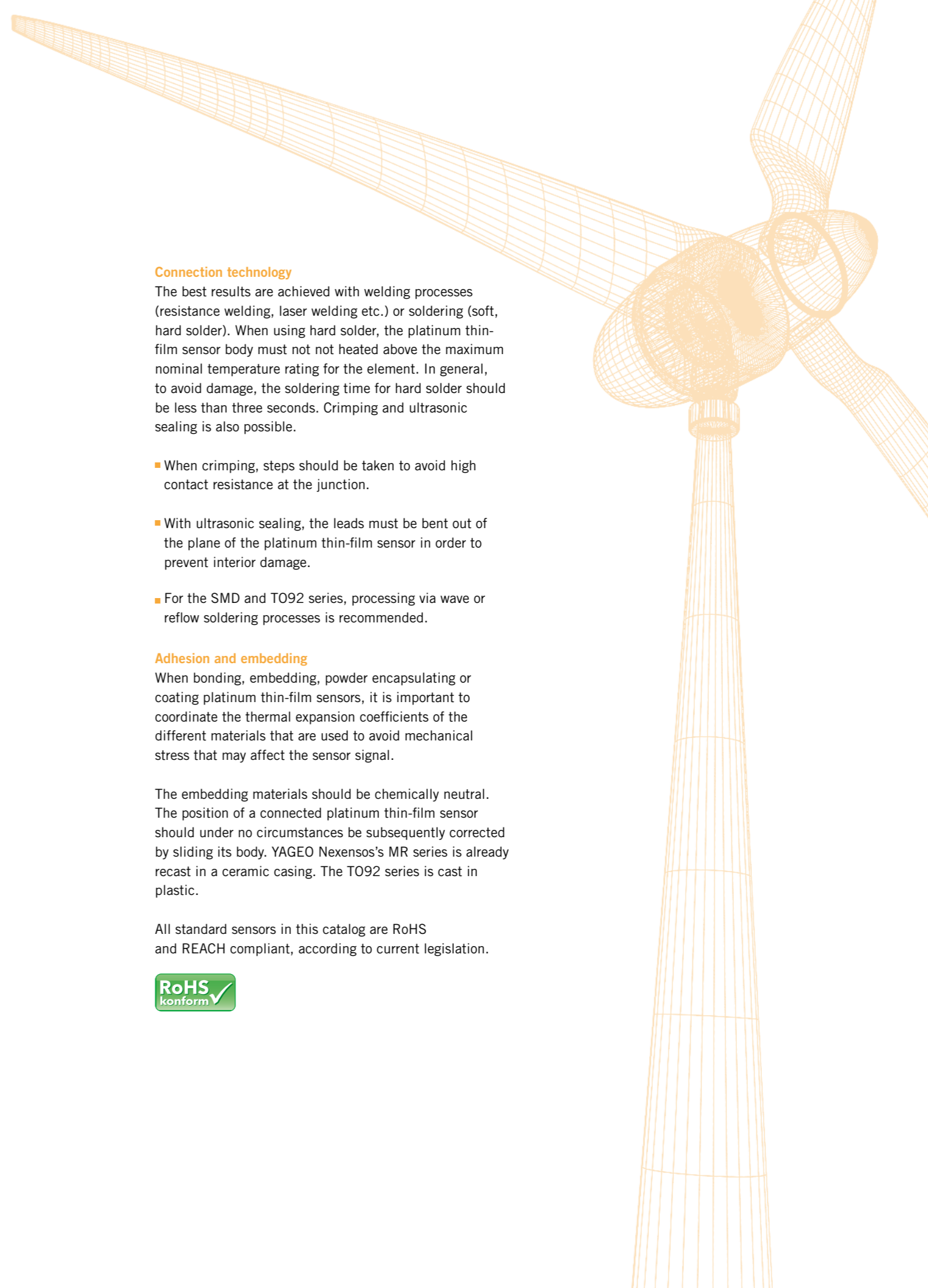

Sensor Elements with wire leads

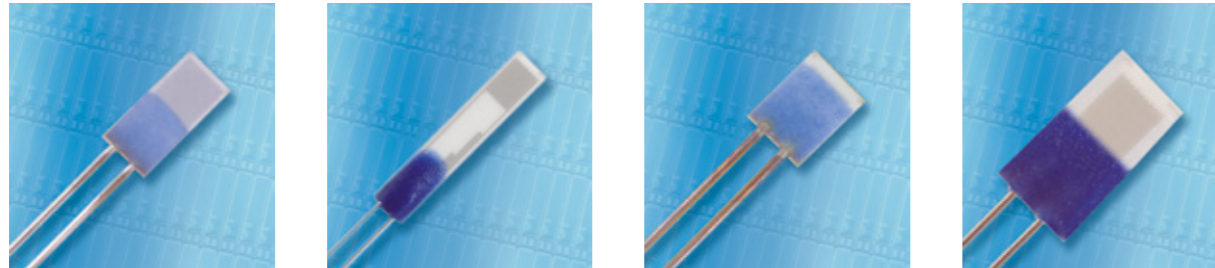

Maximum precision, long-term stability and high resistance make platinum thin-film temperature sensors the sensor of choice in a wide variety of technology sectors.

Driven by our own stimulus for innovation, and motivated by the high demands of our customers, we work constantly further develop and innovate our platinum thin-film technology. The result is a large product portfolio of platinum temperature sensors for measuring temperatures from -196°C to $+1000^{\circ}\text{C}$ with standard resistance values from 100 to 10000 Ω .

The ability to meet high standards and quality demands require the best raw materials, high manufacturing precision and exclusive sensor know-how. This expertise produces sensors that make accurate measurements on a day-to-day basis, millions of times. Excellent chemical and mechanical stability, resistance to moisture, air and other environmental factors result in measurements reproducible and reliable over thousands of cycles.

Our demanding customers apply these advantages by using our sensors to advance the state-of-the-art of their own products. We, as an experienced development partner, are the first port of call for our customers worldwide.

Platinum Temperature Sensor Type C (Cryo)

Temperature range -196°C to $+150^{\circ}\text{C}$

Applications

Cryo applications (analytical equipment, chemical and power generation plants, as well as aerospace)

Specification

DIN EN 60751

Tolerance class

Class F 0.3

Nominal resistances

100 Ω and 1000 Ω at 0°C

Temperature coefficient

3850 ppm/K

Lead wire

AgPd leads

Connection technology

Suitable for soft soldering (Note application temperature of the solder)

Long-term stability

Typical R_0 -drift 0.03% after 1000 h at $+150^{\circ}\text{C}$

Vibration resistance

At least 40 g acceleration at 10 to 2000 Hz, depending on mounting method

Shock resistance

At least 100 g acceleration with 8 ms half sine wave, depending on mounting method

Measuring current

At 100 Ω :
0.3 to 1.0 mA

At 1000 Ω :
0.1 to 0.3 mA (self-heating has to be considered)

Insulation resistance

>100 M Ω at $+20^{\circ}\text{C}/+150^{\circ}\text{C}$

Storage life

At least 12 months (in original packaging)

Supply range

The standard types listed in the catalog with their various features are the most frequently used designs. They can be obtained at short notice and at reasonable prices.

Non-standard versions are available for special applications.

Contact us!

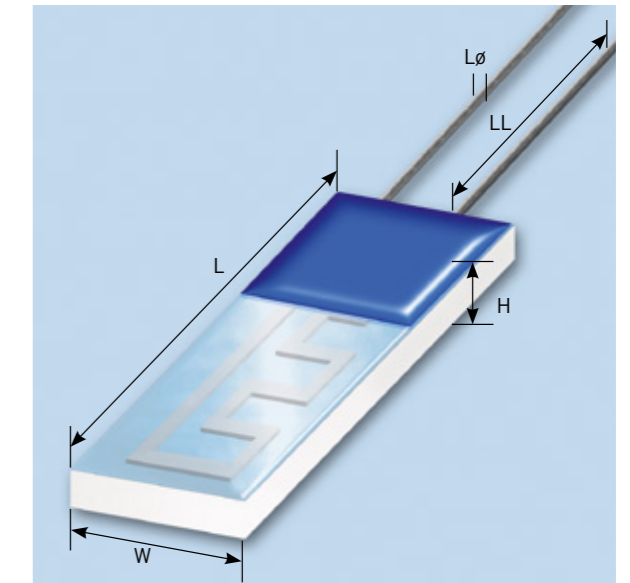

Tolerance class F 0.3 over the temperature range -196°C to $+150^{\circ}\text{C}$

Name		Order number	Dimensions in mm						Self-heating	Response time in seconds			
Type	Design	Nominal resistance	Plastic box/Plastic bag	L	W	H	LL	LØ	Ice water 0°C in K/mW	Water: $v = 0.4 \text{ m/s}$		Air: $v = 2 \text{ m/s}$	
										$t_{0.5}$	$t_{0.9}$	$t_{0.5}$	$t_{0.9}$
C	420	Pt 1000	32207502	3.9	1.9	1.0	15	0.25	0.3	0.08	0.25	3.50	15
C	220	Pt 100	32207399	2.3	1.9	1.0	10	0.25	0.4	0.06	0.20	3.00	13

Tolerances in mm:

L: ± 0.15 • W: ± 0.2 • H: $+ 0.3/-0.2$ • LL: ± 1.0 • LØ: ± 0.02

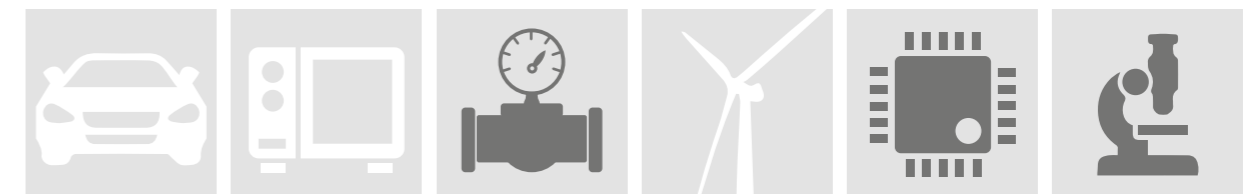

Platinum Temperature Sensor Type L (Low)

Temperature range $-50\text{ }^{\circ}\text{C}$ to $+400\text{ }^{\circ}\text{C}$

Applications

HVAC, process industry; designed for all applications, where good soft solderability is required

Specification

DIN EN 60751

Tolerance class

Class F 0.1
Class F 0.15
Class F 0.3

Nominal resistances

100 Ω and 1000 Ω at $0\text{ }^{\circ}\text{C}$

Temperature coefficient

3850 ppm/K

Lead wire

AgPd leads

Connection technology

Suitable for soft soldering (Note application temperature of the solder)

Long-term stability

Typical R_0 -drift 0.04% after 1000 h at $+400\text{ }^{\circ}\text{C}$

Vibration resistance

At least 40 g acceleration at 10 to 2000 Hz, depending on mounting method

Shock resistance

At least 100g acceleration with 8 ms half sine wave, depending on mounting method

Insulation resistance

> 100 M Ω at $+20\text{ }^{\circ}\text{C}$;
> 2 M Ω at $+400\text{ }^{\circ}\text{C}$

Measuring current

At 100 Ω :
0.3 to 1.0 mA

At 1000 Ω :
0.1 to 0.3 mA (self-heating has to be considered)

Storage life

At least 12 months (in original packaging)

Supply range

The standard types listed in the catalog with their various features are the most frequently used designs. They can be obtained at short notice and at reasonable prices.

Non-standard versions are available for special applications.

Contact us!

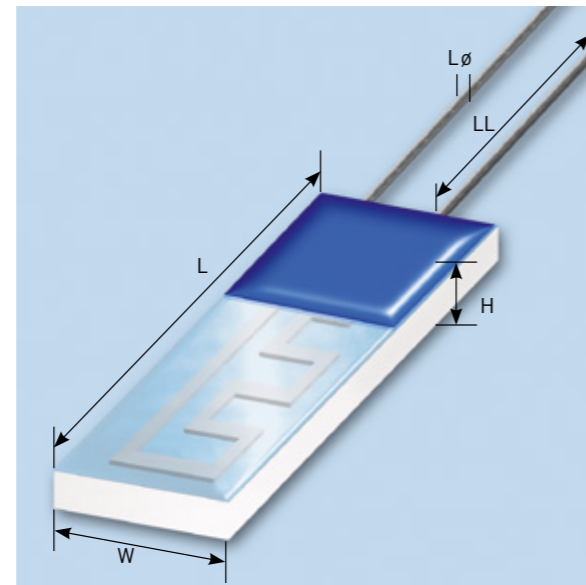

Type L (Low)

Tolerance Class F 0.3 over the temperature range $-50\text{ }^{\circ}\text{C}$ to $+400\text{ }^{\circ}\text{C}$

Name		Order number	Dimensions in mm					Self-heating Ice water $0\text{ }^{\circ}\text{C}$ in K/mW	Response time in seconds				
Type	Design		Nominal resistance	Plastic bag	L	W	H		LL	Lø	Water: v = 0.4 m/s		Air: v = 2 m/s
									t _{0.5}	t _{0.9}	t _{0.5}	t _{0.9}	
L	1020	Pt 1000	32207710	9.5	1.9	1.0	10	0.25	0.2	0.12	0.30	6.0	20
L	420	Pt 1000	32207704	3.9	1.9	1.0	10	0.25	0.3	0.08	0.25	3.5	15
L	416	Pt 100	32207440	3.9	1.5	1.0	10	0.25	0.4	0.07	0.25	3.2	14
L	220	Pt 100	32207400	2.3	1.9	1.0	10	0.25	0.4	0.06	0.20	3.0	13
L	220	Pt 1000	32207733	2.3	1.9	1.0	10	0.25	0.4	0.06	0.20	3.0	13
L	220 P	Pt 100	32207608	2.3	2.0	1.4	10	0.25	0.4	0.20	0.30	3.0	9

Tolerance Class F 0.15 over the temperature range $-50\text{ }^{\circ}\text{C}$ to $+300\text{ }^{\circ}\text{C}$

Name		Order number	Dimensions in mm					Self-heating Ice water $0\text{ }^{\circ}\text{C}$ in K/mW	Response time in seconds				
Type	Design		Nominal resistance	Plastic bag	L	W	H		LL	Lø	Water: v = 0.4 m/s		Air: v = 2 m/s
									t _{0.5}	t _{0.9}	t _{0.5}	t _{0.9}	
L	1020	Pt 1000	32207581	9.5	1.9	1.0	10	0.25	0.2	0.12	0.30	6.0	20
L	420	Pt 1000	32207582	3.9	1.9	1.0	10	0.25	0.3	0.08	0.25	3.5	15
L	416	Pt 100	32207583	3.9	1.5	1.0	10	0.25	0.4	0.07	0.25	3.2	14
L	220	Pt 100	32207584	2.3	1.9	1.0	10	0.25	0.4	0.06	0.20	3.0	13

Tolerance Class F 0.1 over the temperature range $-0\text{ }^{\circ}\text{C}$ to $+150\text{ }^{\circ}\text{C}$

Name		Order number	Dimensions in mm					Self-heating Ice water $0\text{ }^{\circ}\text{C}$ in K/mW	Response time in seconds				
Type	Design		Nominal resistance	Plastic bag	L	W	H		LL	Lø	Water: v = 0.4 m/s		Air: v = 2 m/s
									t _{0.5}	t _{0.9}	t _{0.5}	t _{0.9}	
L	420	Pt 1000	32207587	3.9	1.9	1.0	10	0.25	0.3	0.08	0.25	3.5	15
L	220	Pt 100	32207588	2.3	1.9	1.0	10	0.25	0.4	0.06	0.20	3.0	13

Tolerances in mm:

L: ± 0.15 • W: ± 0.2 • H: $+0.3/-0.2$ • LL: ± 1.0 • Lø: ± 0.02

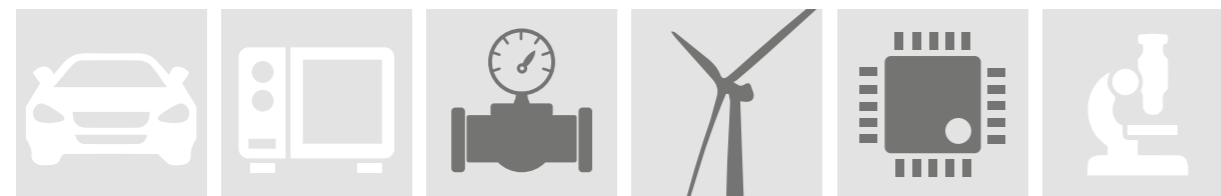

Platinum Temperature Sensor Type LN (Low)

Temperature range $-50\text{ }^{\circ}\text{C}$ to $+400\text{ }^{\circ}\text{C}$

Applications

HVAC, process industry; designed for all applications, where good soft solderability is required

Specification

DIN EN 60751

Tolerance class

Class F 0.15
Class F 0.3

Nominal resistances

100 Ω and 1000 Ω at $0\text{ }^{\circ}\text{C}$

Temperature coefficient

3850 ppm/K

Lead wire

Ni-silver-plated

Connection technology

Suitable for soft soldering (Note application temperature of the solder)

Long-term stability

Typical R_0 -drift 0.04% after 1000 h at $+400\text{ }^{\circ}\text{C}$

Vibration resistance

At least 40 g acceleration at 10 to 2000 Hz, depending on mounting method

Shock resistance

At least 100g acceleration with 8 ms half sine wave, depending on mounting method

Insulation resistance

> 100 M Ω at $+20\text{ }^{\circ}\text{C}$;
> 2 M Ω at $+400\text{ }^{\circ}\text{C}$

Measuring current

At 100 Ω :
0.3 to 1.0 mA

At 500 Ω :

0.1 to 0.7 mA

At 1000 Ω :

0.1 to 0.3 mA (self-heating has to be considered)

Storage life

At least 12 months (in original packaging)

Supply range

The standard types listed in the catalog with their various features are the most frequently used designs. They can be obtained at short notice and at reasonable prices.

Non-standard versions are available for special applications.

Contact us!

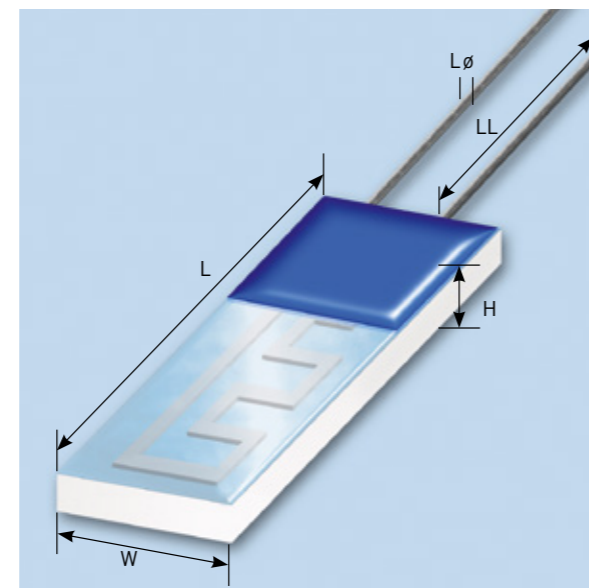

Type LN (Low)

Tolerance Class F 0.3 over the temperature range $-50\text{ }^{\circ}\text{C}$ to $+400\text{ }^{\circ}\text{C}$

Name		Order number		Dimensions in mm					Self-heating	Response time in seconds			
Type	Design	Nominal resistance	Plastic bag	L	W	H	LL	LØ	Ice water $0\text{ }^{\circ}\text{C}$ in K/mW	Water: v = 0.4 m/s		Air: v = 2 m/s	
										$t_{0.5}$	$t_{0.9}$	$t_{0.5}$	$t_{0.9}$
LN	222	Pt 100	32207770	2.3	2.1	0.9	10	0.22	0.4	0.05	0.15	3.0	10
LN	222	Pt 1000	32207772	2.3	2.1	0.9	10	0.22	0.4	0.05	0.15	3.0	10

Tolerance Class F 0.15 over the temperature range $-50\text{ }^{\circ}\text{C}$ to $+300\text{ }^{\circ}\text{C}$

Name		Order number		Dimensions in mm					Self-heating	Response time in seconds			
Type	Design	Nominal resistance	Plastic bag	L	W	H	LL	LØ	Ice water $0\text{ }^{\circ}\text{C}$ in K/mW	Water: v = 0.4 m/s		Air: v = 2 m/s	
										$t_{0.5}$	$t_{0.9}$	$t_{0.5}$	$t_{0.9}$
LN	222	Pt 100	32207771	2.3	2.1	0.9	10	0.22	0.4	0.05	0.15	3.0	10
LN	222	Pt 1000	32207773	2.3	2.1	0.9	10	0.22	0.4	0.05	0.15	3.0	10

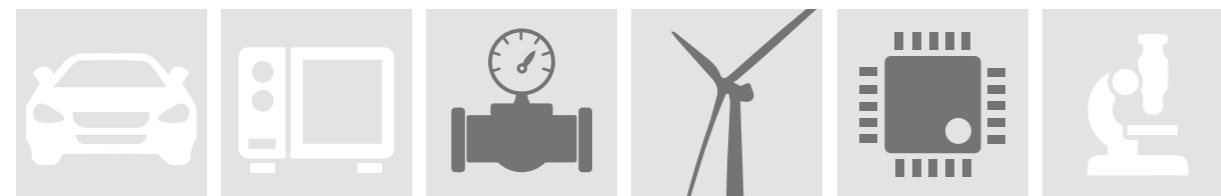

Tolerances in mm:

L: ± 0.15 • W: ± 0.2 • H: $+0.3/-0.2$ • LL: ± 1.0 • LØ: ± 0.02

Platinum Temperature Sensor Type M (Medium)

Temperature range $-70\text{ }^{\circ}\text{C}$ to $+500\text{ }^{\circ}\text{C}$,
short-term up to $+550\text{ }^{\circ}\text{C}$

Applications

Automotive, white goods, ventilation, heating and energy generation, medical and industrial equipment

Specification

DIN EN 60751

Tolerance class

Class F 0.1
Class F 0.15
Class F 0.3

Nominal resistances

100 Ω , 500 Ω , 1000 Ω and 2000 Ω at $0\text{ }^{\circ}\text{C}$.

Temperature coefficient

3850 ppm/K

Lead wire

Pt coated Ni wire

Connection technology

Suitable for welding, brazing and crimping

Long-term stability

Typical R_0 -drift 0.04% after 1000 h at $+500\text{ }^{\circ}\text{C}$

Vibration resistance

At least 40 g acceleration at 10 to 2000 Hz, depending on mounting method

Shock resistance

At least 100g acceleration with 8 ms half sine wave, depending on mounting method

Insulation resistance

> 100 M Ω at $+20\text{ }^{\circ}\text{C}$;
> 2 M Ω at $+500\text{ }^{\circ}\text{C}$

Measuring current

At 100 Ω :
0.3 to 1.0 mA

At 500 Ω :
0.1 to 0.7 mA

At 1000 Ω :
0.1 to 0.3 mA

At 2000 Ω :
0.1 to 0.3 mA
(self-heating has to be considered)

Storage life

At least 12 months
(in original packaging)

Supply range

The standard types listed in the catalog with their various features are the most frequently used designs. They can be obtained at short notice and at reasonable prices.

Non-standard versions are available for special applications.

Contact us!

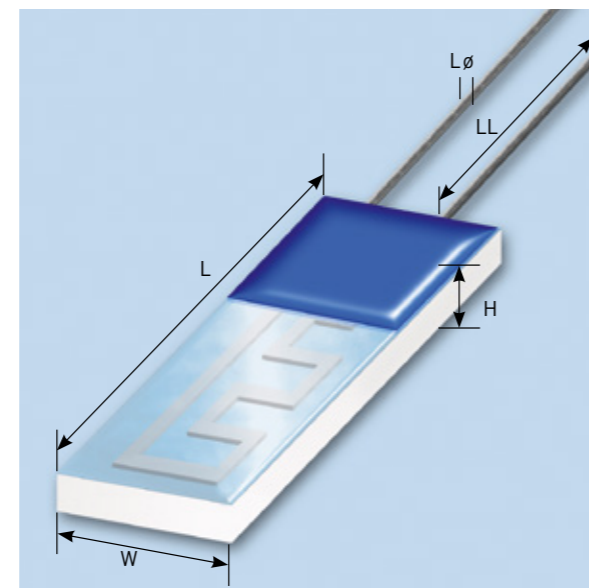

Type M (Medium)

Tolerance Class F 0.3 over the temperature range $-70\text{ }^{\circ}\text{C}$ to $+500\text{ }^{\circ}\text{C}$ TK 3850

Type	Design	Nominal resistance	Order number		Dimensions in mm					Self-heating Ice water $0\text{ }^{\circ}\text{C}$ in K/mW	Response time in seconds			
			Blister reel	Plastic bag	L	W	H	LL	L \emptyset		Water: v = 0.4 m/s		Air: v = 2 m/s	
											t _{0.5}	t _{0.9}	t _{0.5}	t _{0.9}
M	1020	Pt 100	32208280	32208180	9.5	1.9	0.9	10	0.2	0.2	0.10	0.30	4.0	12
M	1020	Pt 1000	32208286	32208191	9.5	1.9	0.9	10	0.2	0.2	0.10	0.30	4.0	12
M	620	Pt 2000		32208541	5.9	2.1	0.9	10	0.2	0.3	0.08	0.25	3.7	11.5
M	422	Pt 100	32208520	32208392	3.9	2.1	0.9	10	0.2	0.3	0.07	0.20	3.2	11
M	422	Pt 500	32208523	32208414	3.9	2.1	0.9	10	0.2	0.3	0.07	0.20	3.2	11
M	422	Pt 1000	32208526	32208499	3.9	2.1	0.9	10	0.2	0.3	0.07	0.20	3.2	11
M	416	Pt 100	32208278	32208213	3.9	1.5	0.9	10	0.2	0.4	0.06	0.18	3.1	10.5
M	310	Pt 100	32208721	5014252	3.0	1.0	0.8	10	0.15	0.4	0.04	0.12	2.5	8
M	310	Pt 1000	32208723	5014253	3.0	1.0	0.8	10	0.15	0.4	0.04	0.12	2.5	8
M	222	Pt 100	32208718	32208548	2.3	2.1	0.9	10	0.2	0.4	0.05	0.15	3.0	10
M	222	Pt 500		32208706	2.3	2.1	0.9	10	0.2	0.4	0.05	0.15	3.0	10
M	222	Pt 1000		32208571	2.3	2.1	0.9	10	0.2	0.4	0.05	0.15	3.0	10
M	220	Pt 100	32208440	32208714	2.3	1.9	0.9	10	0.2	0.4	0.05	0.15	3.0	10
M	213	Pt 100		32207690	1.7	1.25	0.8	10	0.15	0.6	0.04	0.12	2.2	7
M	213	Pt 1000		32207695	1.7	1.25	0.8	10	0.15	0.6	0.04	0.12	2.2	7

Tolerance Class F 0.15 over the temperature range $-50\text{ }^{\circ}\text{C}$ to $+300\text{ }^{\circ}\text{C}$ TK 3850

Type	Design	Nominal resistance	Order number		Dimensions in mm					Self-heating Ice water $0\text{ }^{\circ}\text{C}$ in K/mW	Response time in seconds			
			Blister reel	Plastic bag	L	W	H	LL	L \emptyset		Water: v = 0.4 m/s		Air: v = 2 m/s	
											t _{0.5}	t _{0.9}	t _{0.5}	t _{0.9}
M	1020	Pt 100	32208429		9.5	1.9	0.9	10	0.2	0.2	0.10	0.30	4.0	12
M	1020	Pt 1000	32208439		9.5	1.9	0.9	10	0.2	0.2	0.10	0.30	4.0	12
M	422	Pt 100	32208521	32208498	3.9	2.1	0.9	10	0.2	0.3	0.07	0.20	3.2	11
M	422	Pt 500	32208524	32208501	3.9	2.1	0.9	10	0.2	0.3	0.07	0.20	3.2	11
M	422	Pt 1000	32208527	32208503	3.9	2.1	0.9	10	0.2	0.3	0.07	0.20	3.2	11
M	416	Pt 100	32208279	32208216	3.9	1.5	0.9	10	0.2	0.4	0.06	0.18	3.1	10.5
M	310	Pt 100	32208725	5014254	3.0	1.0	0.8	10	0.15	0.4	0.04	0.12	2.5	8
M	310	Pt 1000	32208727	5014255	3.0	1.0	0.8	10	0.15	0.4	0.04	0.12	2.5	8
M	222	Pt 100		32208550	2.3	2.1	0.9	10	0.2	0.4	0.05	0.15	3.0	10
M	222	Pt 1000		32208572	2.3	2.1	0.9	10	0.2	0.4	0.05	0.15	3.0	10
M	220	Pt 100	32208465	32208715	2.3	1.9	0.9	10	0.2	0.4	0.05	0.15	3.0	10
M	213	Pt 100		32207691	1.7	1.25	0.8	10	0.15	0.6	0.04	0.12	2.2	7

Tolerances in mm:

L: ± 0.15 (M 213: L: ± 0.25) • W: ± 0.15 (at X 22: W: ± 0.2) • H: $+0.3 / -0.2$ • LL: ± 1.0 • L \emptyset : ± 0.02

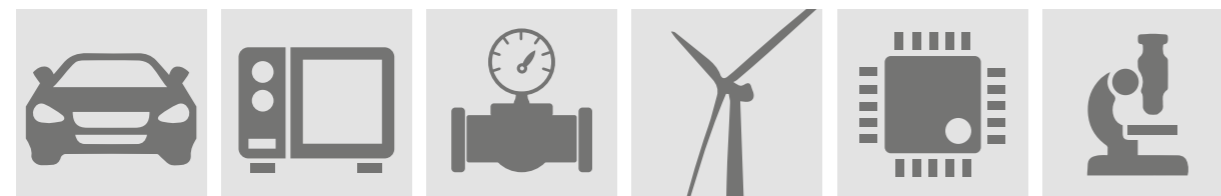

Type M (Medium)

Tolerance Class F 0.1 over the temperature range 0 °C to +150 °C										TK 3850				
Type	Design	Name		Dimensions in mm					Self-heating Ice water 0 °C in K/mW	Response time in seconds				
		Nominal resistance	Order number	Blister reel	Plastic bag	L	W	H		LL	LØ	Water: v = 0.4 m/s		Air: v = 2 m/s
										t _{0.5}	t _{0.9}	t _{0.5}	t _{0.9}	
M	1020	Pt 100	32208428		9.5	1.9	0.9	10	0.2	0.2	0.10	0.30	4.0	12
M	1020	Pt 1000	32208483		9.5	1.9	0.9	10	0.2	0.2	0.10	0.30	4.0	12
M	422	Pt 100	32208522	32208500	3.9	2.1	0.9	10	0.2	0.3	0.07	0.20	3.2	11
M	422	Pt 500		32208502	3.9	2.1	0.9	10	0.2	0.3	0.07	0.20	3.2	11
M	422	Pt 1000		32208537	3.9	2.1	0.9	10	0.2	0.3	0.07	0.20	3.2	11
M	416	Pt 100		32208217	3.9	1.5	0.9	10	0.2	0.4	0.06	0.18	3.1	10.5
M	222	Pt 100		32208551	2.3	2.1	0.9	10	0.2	0.4	0.05	0.15	3.0	10
M	222	Pt 1000		32208707	2.3	2.1	0.9	10	0.2	0.4	0.05	0.15	3.0	10
M	220	Pt 100	32208466		2.3	1.9	0.9	10	0.2	0.4	0.05	0.15	3.0	10
M	213	Pt 100		32207692	1.7	1.25	0.8	10	0.15	0.6	0.04	0.12	2.2	7

Tolerances in mm:

L: ± 0.15 (M 213: L: ± 0.25) • W: ± 0.15 (at X 22: W: ± 0.2) • H: + 0.3 / -0.2 • LL: ± 1.0 • LØ: ± 0.02



Platinum Temperature Sensor MR 828 and 845

Temperature range $-70\text{ }^{\circ}\text{C}$ to $+500\text{ }^{\circ}\text{C}$ (continuous operation), short-term up to $+550\text{ }^{\circ}\text{C}$

Applications

Analytical and medical equipment, chemical plants and mechanical equipment

Specification

DIN EN 60751

Tolerance class

Class F 0.3

Nominal resistances

100 Ω , 500 Ω and 1000 Ω at $0\text{ }^{\circ}\text{C}$

Temperature coefficient

3850 ppm/K

Lead wire

Pt clad Ni wire

Connection technology

Welding, brazing and crimping

Long-term stability

Typical R_0 -drift 0.1% after 1000 h at $+500\text{ }^{\circ}\text{C}$

Vibration resistance

According to DIN EN 60751

Insulation resistance

$> 100\text{ M}\Omega$ at $+20\text{ }^{\circ}\text{C}$;
 $> 2\text{ M}\Omega$ at $+500\text{ }^{\circ}\text{C}$

Measuring current

100 Ω : 0.3 to 1.0 mA

500 Ω : 0.1 to 0.7 mA

1000 Ω : 0.1 to 0.3 mA
(self-heating has to be considered)

Note

Other tolerances and values of resistance are available on request.

Contact us!

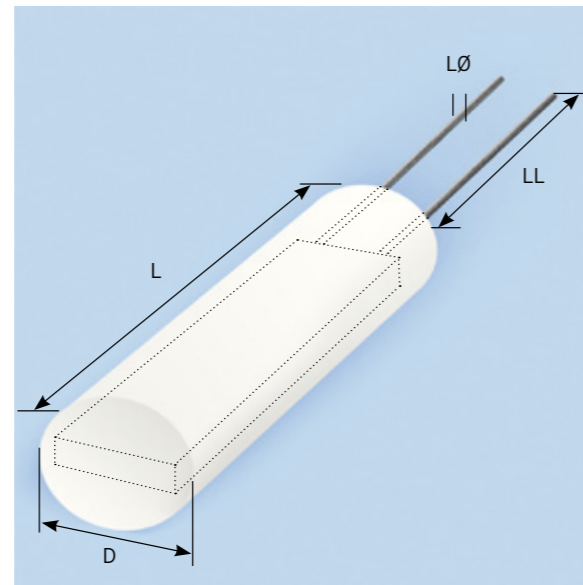

Tolerance Class F 0.3 over the temperature range $-70\text{ }^{\circ}\text{C}$ to $+500\text{ }^{\circ}\text{C}$

Type	Name		Order number Blister reel	Dimension in mm	Self-heating Ice water $0\text{ }^{\circ}\text{C}$ in K/mW	Response time in seconds			
	Design	Nominal resistance				Water: $v = 0.4\text{ m/s}$		Air: $v = 2\text{ m/s}$	
						$t_{0.5}$	$t_{0.9}$	$t_{0.5}$	$t_{0.9}$
MR	828	Pt 100	32209340	L=8 D=2.8 LL=6 LØ=0.2	0.05	0.9	2.7	12.3	39.5
MR	828	Pt 1000	32209342		0.05	0.9	2.7	12.3	39.5
MR	828	2 Pt 100	32209343		0.16	0.9	2.7	12.3	39.5

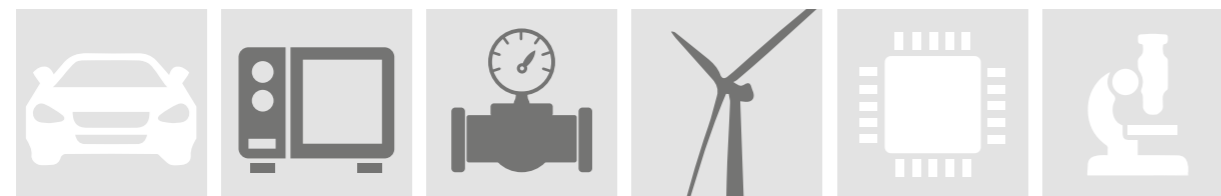

Tolerances in mm:

L: ± 0.25 • D: ± 0.3 • LL: $+2/-1$ • LØ: ± 0.01

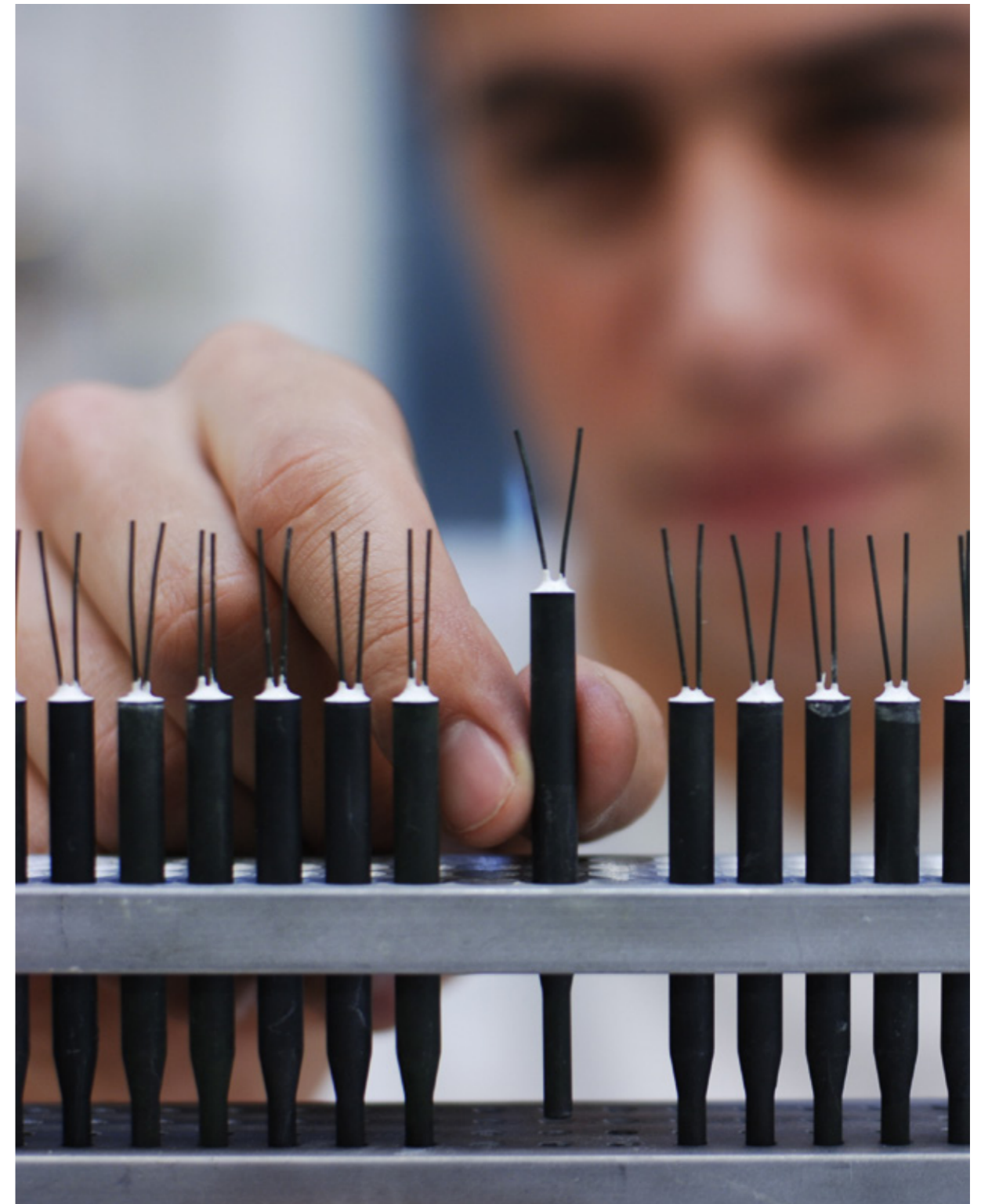

Platinum Temperature Sensor Type H (High)

Temperature range $-70\text{ }^{\circ}\text{C}$ to $+750\text{ }^{\circ}\text{C}$ (HL),
 $-70\text{ }^{\circ}\text{C}$ to $+850\text{ }^{\circ}\text{C}$ (HD), $-40\text{ }^{\circ}\text{C}$ to $+900\text{ }^{\circ}\text{C}$ (HDA)

Applications

Used in applications with high consumption volumes, typically in the automotive, white goods, heating power and process technology fields

Specification

DIN EN 60751
 HNE specification

Tolerance class

Class F 0.3
 Class F 0.6

Nominal resistances

100Ω and 1000Ω at 0°C

Temperature coefficient

3850 ppm/K (HL, HD)
 3770 ppm/K (HDA)

Lead wire

PtPd, PtNiCr, Pt leads

Connection technology

Suitable for welding and brazing

Long-term stability

HL: 1000 h at $+750\text{ }^{\circ}\text{C}$ (energized)*
 HD: 1000 h at $+850\text{ }^{\circ}\text{C}$ (energized, open)*,
 1000 h at $+650\text{ }^{\circ}\text{C}$ (energized in MI)*

*Smaller than DIN EN 60751

HDA: 500 h at $+900\text{ }^{\circ}\text{C}$ **
 500 cycles: room temperature ($+25\text{ }^{\circ}\text{C}$), to $+900\text{ }^{\circ}\text{C}$ **

** $(5\text{V, pre-resistor } 1000\text{ }\Omega)$,
 R_0 typical $< 2.5\text{ K}$

Vibration resistance

At least 40 g acceleration at 10 to 2000 Hz, depending on mounting method

Shock resistance

At least 100 g acceleration with 8 ms half sine wave, depending on mounting method

Environmental conditions

Up to $+600\text{ }^{\circ}\text{C}$, fitting in cleaner MI version is also possible, above $+600\text{ }^{\circ}\text{C}$ no reducing atmospheres, air access must be ensured.

HD version:

Up to $+650\text{ }^{\circ}\text{C}$, fitting in cleaner MI version is also possible, above $+650\text{ }^{\circ}\text{C}$ no reducing atmospheres, air access must be ensured.

Insulation resistance

$> 100\text{ M}\Omega$ at $+20\text{ }^{\circ}\text{C}$;
 $> 2\text{ M}\Omega$ at $+650\text{ }^{\circ}\text{C}$

Measuring current

100 Ω:
 0.3 to max. 1 mA

200 Ω:
 $+20\text{ }^{\circ}\text{C}$ max. 5.0 mA;
 $+900\text{ }^{\circ}\text{C}$ max. 2.8 mA (self-heating has to be considered)

1000 Ω:
 0.1 to max. 0.3 mA (self-heating has to be considered)

Storage life

At least 12 months (in original packaging)

Supply range

The standard types listed in the catalog with their various features are the most frequently used designs. They can be obtained at short notice and at reasonable prices.

Non-standard versions are available for special applications.

Contact us!

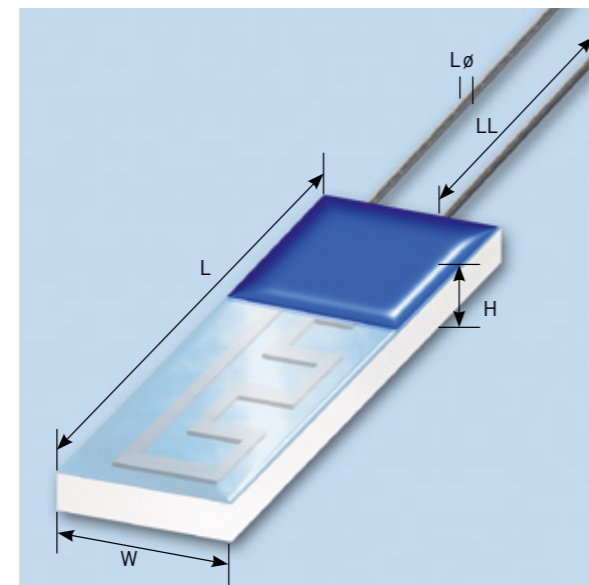

Type H (High)

Tolerance Class F 0.6 over the temperature range $-70\text{ }^{\circ}\text{C}$ to $+750\text{ }^{\circ}\text{C}$, TK = 3850 ppm/K

Name		Order number		Dimensions in mm						Self-heating	Response time in seconds			
Type	Design	Nominal resistance	Please ask	Leads material	L	W	H	LL	LØ	Ice water 0°C in K/mW	Water: v = 0.4 m/s		Air: v = 2 m/s	
											t _{0.5}	t _{0.9}	t _{0.5}	t _{0.9}
HL	220	Pt 1000	32208779	PtNiCr	2.3	1.9	1.0	8	0.2	0.2	≤ 0.05	≤ 0.14	≤ 3	≤ 10

Tolerances in mm:

L: ± 0.15 • W: ± 0.15 • H: ± 0.3 • LL: ± 1.0 • LØ: ± 0.04

Tolerance Class F 0.3 over the temperature range $-70\text{ }^{\circ}\text{C}$ to $+650\text{ }^{\circ}\text{C}$; TK = 3850 ppm/K and
 Tolerance Class F 0.6 over the temperature range $-70\text{ }^{\circ}\text{C}$ to $+850\text{ }^{\circ}\text{C}$; TK = 3850 ppm/K

Name		Order number		Dimensions in mm						Self-heating	Response time in seconds			
Type	Design	Nominal resistance	Please ask	Leads material	L	W	H	LL	LØ	Ice water 0°C in K/mW	Water: v = 0.4 m/s		Air: v = 2 m/s	
											t _{0.5}	t _{0.9}	t _{0.5}	t _{0.9}
HD	421	Pt 100	32208228	Pt	4.1	2.2	1.2	6	0.25	0.2	0.05	0.17	3.3	13

Tolerances in mm:

L: ± 0.3 • W: $+ 0.3 / - 0.2$ • H: ± 0.3 • LL: ± 1.0 • LØ: ± 0.04

Temperature range $-40\text{ }^{\circ}\text{C}$ to $+900\text{ }^{\circ}\text{C}$ (tolerances see table on website), TK = 3770 ppm/K

Name		Order number		Dimensions in mm						Self-heating	Response time in seconds			
Type	Design	Nominal resistance	Please ask	Leads material	L	W	H	LL	LØ	Ice water 0°C in K/mW	Water: v = 0.4 m/s		Air: v = 2 m/s	
											t _{0.5}	t _{0.9}	t _{0.5}	t _{0.9}
HDA	420	Pt 200	32208775	5052797	3.9	1.9	1.0	3.7	0.25	0.2	0.05	0.17	3.3	11

Tolerances in mm:

L: ± 0.15 • W: ± 0.2 • H: ± 0.3 • LL: $+ 0.3 / - 0.2$ • LØ: ± 0.02

YAGEO Nexensos-Sensors up to $+1000\text{ }^{\circ}\text{C}$

Please ask for projects for sensors up to $+1000\text{ }^{\circ}\text{C}$

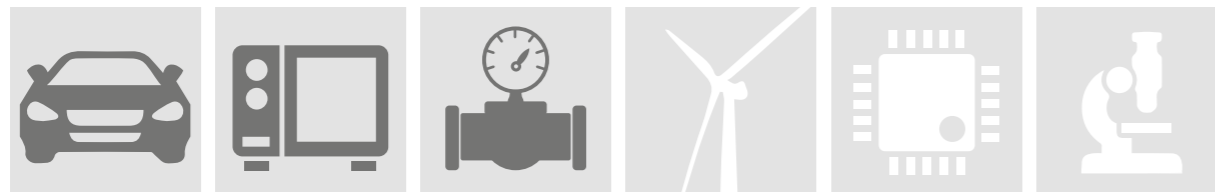

Platinum Sensors for electronic circuits

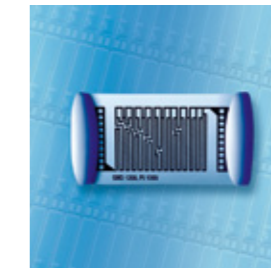

Precision, safety and long-term stability are critical success factors for the development and production of applications and solutions requiring high-accuracy temperature measurements.

The outstanding properties of the sensor components, combined with the capacity for high quality, high volume production, provide our customers with the ability to enhance their own products with the benefits of platinum sensor technology. Standardized designs also allow for automated processing; a key advantage for cost reduction. Platinum sensor components used in the process technology, power & energy management, home appliances, automotive technology, electronics, and life science take advantage of these benefits.

The close partnership with our customers is of the highest importance; it provides the basis for our unique achievements. With our own basic research capability, and in close collaboration with universities and research institutes, we create the prerequisites for your innovative and future-oriented applications.

With extensive experience and expertise in the field of structured thin platinum films, YAGEO Nexensos is your contact partner for cutting-edge sensor solutions.

Platinum Temperature Sensor SMD

Temperature range $-50\text{ }^{\circ}\text{C}$ to $+150\text{ }^{\circ}\text{C}^*$

*Application temperatures of $+150\text{ }^{\circ}\text{C}$ are only possible with the use of expansion-matched circuit board material (Up to $+130\text{ }^{\circ}\text{C}$ with circuit board material not matched for expansion)

Applications

Temperature detection on circuit boards, designed for automatic assembly in large-scale applications

Specification

DIN EN 60751

Tolerance class

Class F 0.3
Class F 0.6

Nominal resistances

100 Ω , 1000 Ω
at $0\text{ }^{\circ}\text{C}$

Temperature coefficient

3850 ppm/K

Connection technology

SMD-V: galvanic tin plated with Ni-barrier

Long-term stability

Max. R_0 -drift 0.06 %
after 250 h at $+150\text{ }^{\circ}\text{C}$

Insulation resistance

$> 10\text{ M}\Omega$ at $+20\text{ }^{\circ}\text{C}$

Measuring current

At 100 Ω :
0.3 to 1.0 mA

At 1000 Ω :

0.1 to 0.3 mA
(self-heating has to be considered)

Application

Face-up mounting:
Reflow soldering or wave soldering, e.g. double wave

Storage life

At least 12 months
(in original packaging)

Supply range

The standard types listed in the catalog with their various features are the most frequently used designs. They can be obtained at short notice and at reasonable prices.

Non-standard versions are available for special applications.

Contact us!

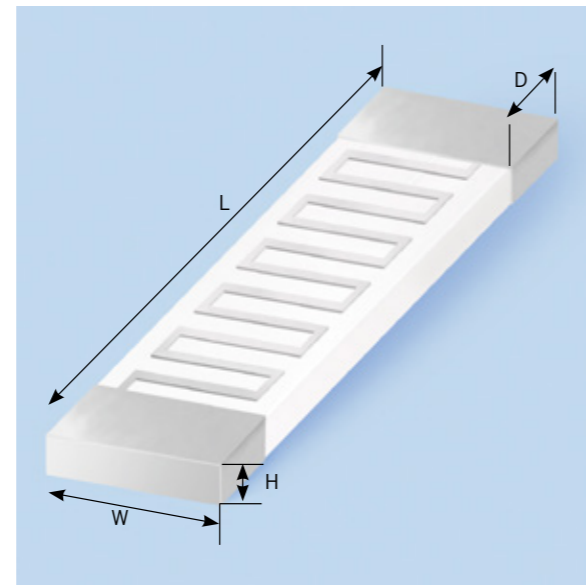

SMD

Tolerance Class F 0.6 over the temperature range $-50\text{ }^{\circ}\text{C}$ to $+150\text{ }^{\circ}\text{C}^*$; $R_0: \pm 0.24\%$

Face up

Type	Name		Order number	Dimensions in mm				Self-heating Ice water $0\text{ }^{\circ}\text{C}$ in K/mW	Response time in seconds			
	Design	Nominal resistance		L	W	H	D		Water: $v = 0.4\text{ m/s}$		Air: $v = 2\text{ m/s}$	
			Blister reel					$t_{0.5}$	$t_{0.9}$	$t_{0.5}$	$t_{0.9}$	
SMD	1206 V	Pt 100	32207589	3.2	1.6	0.6	0.5	0.4	0.15	0.30	3.5	10
SMD	1206 V	Pt 1000	32207594	3.2	1.6	0.6	0.5	0.4	0.15	0.30	3.5	10
SMD	0805 V	Pt 100	32207604	2.3	1.4	0.6	0.5	0.8	0.10	0.25	2.5	8
SMD	0805 V	Pt 1000	32207614	2.3	1.4	0.6	0.5	0.8	0.10	0.25	2.5	8
SMD	0805 V	Pt 10000	32208655	2.3	1.4	0.6	0.5	0.8	0.10	0.25	2.5	8
SMD	0603 V	Pt 1000	32207637	1.7	0.9	0.45	0.3	0.8	0.10	0.25	2.5	8

Tolerance Class F 0.3 over the temperature range $-50\text{ }^{\circ}\text{C}$ to $+150\text{ }^{\circ}\text{C}^*$; $R_0: \pm 0.12\%$

Face up

Type	Name		Order number	Dimensions in mm				Self-heating Ice water $0\text{ }^{\circ}\text{C}$ in K/mW	Response time in seconds			
	Design	Nominal resistance		L	W	H	D		Water: $v = 0.4\text{ m/s}$		Air: $v = 2\text{ m/s}$	
			Blister reel					$t_{0.5}$	$t_{0.9}$	$t_{0.5}$	$t_{0.9}$	
SMD	1206 V	Pt 100	32207590	3.2	1.6	0.6	0.5	0.4	0.15	0.30	3.5	10
SMD	1206 V	Pt 1000	32207595	3.2	1.6	0.6	0.5	0.4	0.15	0.30	3.5	10
SMD	0805 V	Pt 100	32207605	2.3	1.4	0.6	0.5	0.8	0.10	0.25	2.5	8
SMD	0805 V	Pt 1000	32207615	2.3	1.4	0.6	0.5	0.8	0.10	0.25	2.5	8
SMD	0603 V	Pt 1000	32207638	1.7	0.9	0.45	0.3	0.8	0.10	0.25	2.5	8

Tolerances in mm:

L: ± 0.2 • W: ± 0.2 • H: ± 0.1 • D: ± 0.2

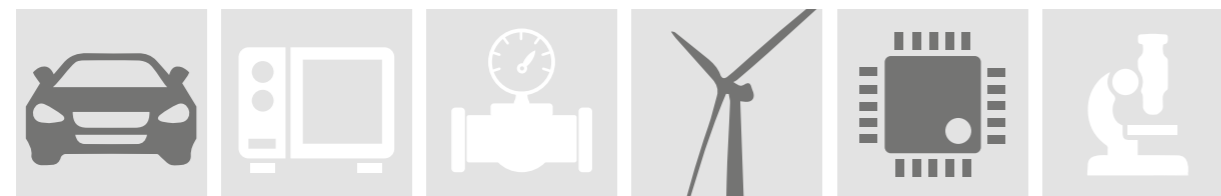

Platinum Temperature Sensor SMD

Solderability test of SMD sensor elements

Mounting conditions

Layout of the circuit board: Benchmark II
150 Qm (Material FR4)
35 Qm Cu, size
190.5 x 127 x 1.5 mm)

Circuit board surfaces:
chem. Ag, Cu OSP, NiAu,
chem. Sn

Soldering paste: F640
SA30C5-89 M30 (Material SnAgCu 96.5/3.0/0.5)

Types tested
Pt 1000 SMD- V 0603
Pt 1000 SMD- V 0805
Pt 1000 SMD- V 1206

Soldering conditions

Limit profiles: Atmosphere:
High and Low Nitrogen and air

Result
All tested components exhibit sufficient wetting under the High and Low limit profiles, based on a visual solder joint inspection.

High and Low limit profiles for reflow soldering

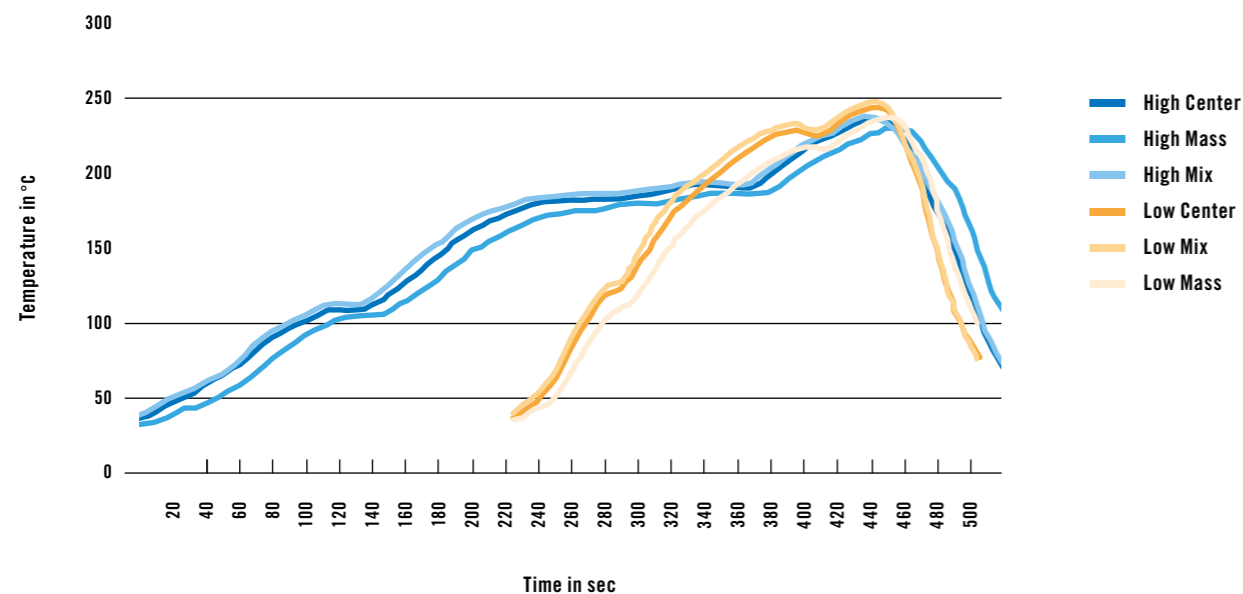

High and Low limit profiles for reflow soldering

	Peak (max. temperature)		Time over +217°C in sec	
	High	Low	High	Low
Center ¹	+237°C	+245°C	60	92
Mass ²	+231°C	+238°C	49	68
Mix ³	+238°C	+248°C	65	103

Center¹: Position of temperature sensor in the centre of the circuit board
Mass²: Position of the temperature sensor on a large mass on the circuit board
Mix³: Position of temperature sensor left and right on the circuit board

High limit profile: Total throughput time 520 sec
Low limit profile: Total throughput time 280 sec

Platinum Temperature Sensor SMD-SC

Temperature range -50 °C to +200 °C

Applications

Temperature detection on power electronics modules for industry and automotive

Specification

DIN EN 60751

Tolerance class

F 0.6

Nominal resistance

1000 Ω at 0 °C

Temperature coefficient

3850 ppm/K

Long-term stability

Max. R₀-drift ≤ 0.23% after 1000 h at +200 °C, ≥ 0.1 mA
after 1000 h at +85 °C, 85% r.F.
after 1000 cycles at +150 °C/-40 °C

Self-heating

< 0,4 K/mW (unassembled)

Insulation resistance

> 1000 MΩ at +20 °C

Measuring current

1000 Ω: 0.1 to 0.3 mA (self-heating has to be considered)

Top side metallization (bonding)

AgPt surface in thick film technology for thick wire ultrasonic bonding process.

Recommendation: Heraeus Al H11 thick wires (Ø 300 µm). All tests were done with recommended wire (see above).

Back side metallization (sintering)

AgPd surface in thick film technology for silver sintering process.

Recommendation: Heraeus sinter paste (ASP 338 and 043 series). All tests were done with recommended paste (see above).

Supply range

SMD-SC 1206 is delivered on a wafer frame, which enables automated pick-and-place and protects the substrates at the best until processing.

Contact us!

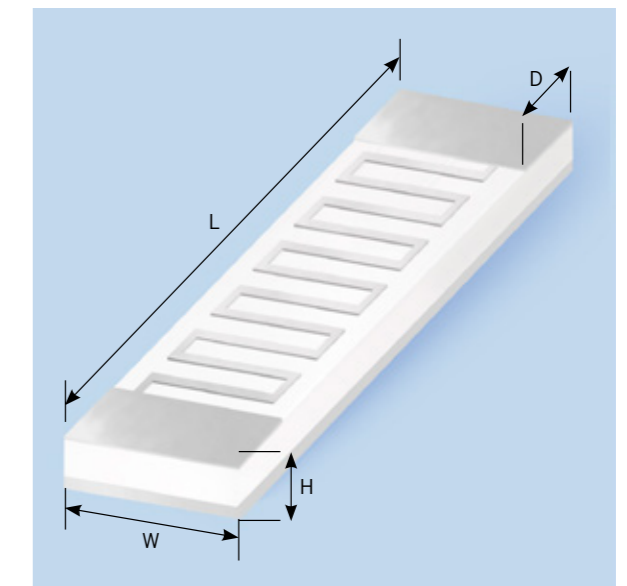

Tolerance class F 0.6 over the temperature range -50 °C to +200 °C

Name	Order number	Dimensions in mm
Type Design Nominal resistance	Substrate on wafer frame in plastic bag	L W H D
SMD 1206 SC Pt 1000	5033344	3.1 1.5 0.55 0.79

Tolerances in mm:

L: ± 0.15 • W: ± 0.15 • H: ± 0.15 • D: ± 0

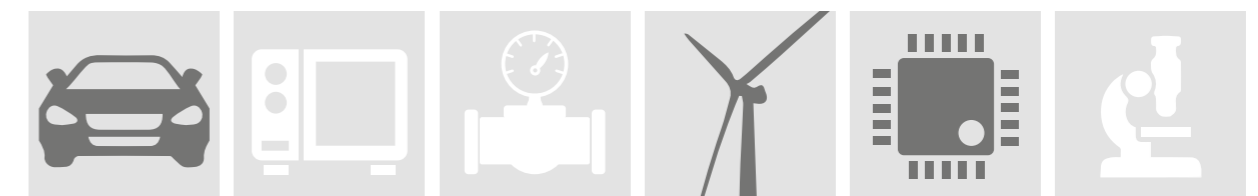

Platinum Temperature Sensor SMD-FC

Temperature range $-50\text{ }^{\circ}\text{C}$ to $+150\text{ }^{\circ}\text{C}$
on ceramic hybrid up to $+170\text{ }^{\circ}\text{C}$

Applications
Hybrid circuits

Specification
DIN EN 60751

Tolerance class
Class F 0.3

Nominal resistances
100 Ω and 1000 Ω
at $0\text{ }^{\circ}\text{C}$

Temperature coefficient
3850 ppm/K

Connection technology
Silver alloy

Long-term stability
 R_0 -drift $\geq 0.06\%$ after
1000 h at $+170\text{ }^{\circ}\text{C}$

Insulation resistance
 $> 10\text{ M}\Omega$ at $+20\text{ }^{\circ}\text{C}$
 $> 1\text{ M}\Omega$ at $+170\text{ }^{\circ}\text{C}$
(glass coverage)

Measuring current
At 100 Ω :
0.3 to 1.0 mA

At 1000 Ω :
0.1 to 0.3 mA
(self-heating has to be
considered)

Environmental conditions
Unhoused only in dry
environment

Processing instructions
Mounting using SMD
pick-&-place machines is
recommended.
When mounting on PCB
circuits, the expansion
properties of the sensor
and carrier material must
be taken into account.

Storage life
At least 12 months
(in original packaging)

Supply range
The standard types listed in the catalog with their various
features are the most frequently used designs. They can
be obtained at short notice and at reasonable prices.

Non-standard versions are available for special
applications.

Contact us!

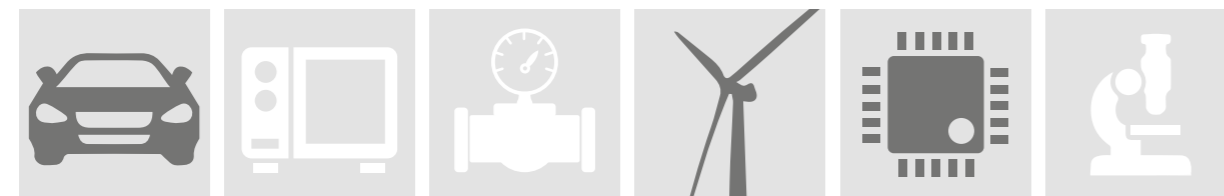
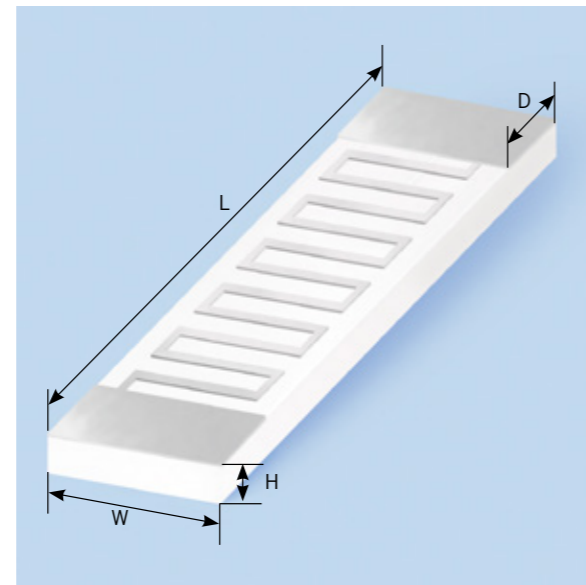

SMD-FC

Tolerance Class F 0.6 over the temperature range $-50\text{ }^{\circ}\text{C}$ to $+170\text{ }^{\circ}\text{C}^*$; $R_0: \pm 0.24\%$									Face down			
Type	Name		Order number	Dimensions in mm				Self-heating Ice water $0\text{ }^{\circ}\text{C}$ in K/mW	Response time in seconds			
	Design	Nominal resistance		Blister reel	L	W	H		D	Water: $v = 0.4\text{ m/s}$		Air: $v = 2\text{ m/s}$
								$t_{0.5}$	$t_{0.9}$	$t_{0.5}$	$t_{0.9}$	
SMD	0805 FC	Pt 100	32208595	2.1	1.35	0.4	0.4	0.8	0.10	0.25	2.5	8
SMD	0805 FC	Pt 1000	32208570	2.1	1.35	0.4	0.4	0.8	0.15	0.25	2.5	8

Tolerance Class F 0.3 over the temperature range $-50\text{ }^{\circ}\text{C}$ to $+170\text{ }^{\circ}\text{C}^*$; $R_0: \pm 0.12\%$									Face down			
Type	Name		Order number	Dimensions in mm				Self-heating Ice water $0\text{ }^{\circ}\text{C}$ in K/mW	Response time in seconds			
	Design	Nominal resistance		Blister reel	L	W	H		D	Water: $v = 0.4\text{ m/s}$		Air: $v = 2\text{ m/s}$
								$t_{0.5}$	$t_{0.9}$	$t_{0.5}$	$t_{0.9}$	
SMD	0805 FC	Pt 100	32208594	2.1	1.35	0.4	0.4	0.8	0.10	0.25	2.5	8
SMD	0805 FC	Pt 1000	32208569	2.1	1.35	0.4	0.4	0.8	0.15	0.25	2.5	8

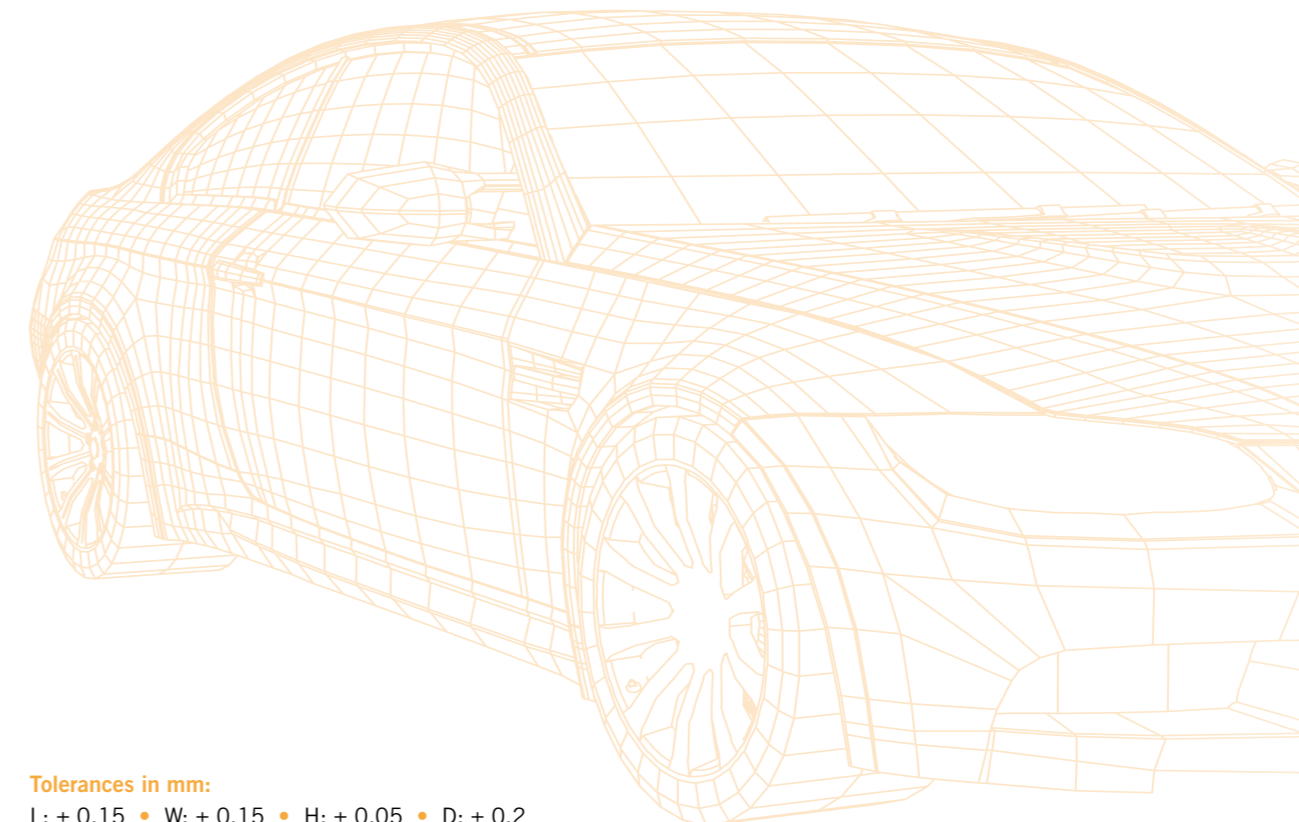

Tolerances in mm:
L: ± 0.15 • W: ± 0.15 • H: ± 0.05 • D: ± 0.2

Sensor elements on a PCB

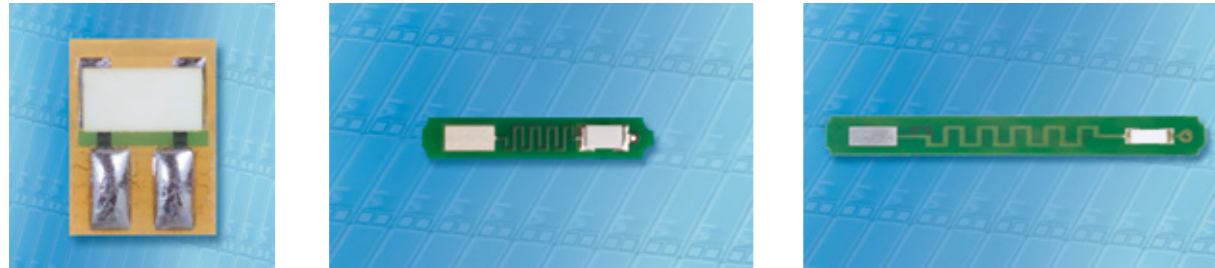

The temperature sensor market sets a large number of stringent requirements for the development of individual and specific solutions. By way of close and coordinated cooperation from the beginning of the development process, to the series production in highest quantities, we offer our customers the opportunity to combine our strengths to maximize results.

Examples of products developed in collaboration with our customers include temperature sensors for installation in ovens and sealed cooktops, engine-oil condition sensors subject to strong vibrations, calorimetric measurement instruments, as well as in resistance thermometers for the process industry. We have been also successful in implementing custom designed platform chips that incorporate sensors and heating elements in a single component.

Production quality is particularly important to us. The production processes are continually optimized via the principle of continuous improvement, helping us to provide our partners with high quality, low-cost competitive solutions.

Platinum Temperature Sensor PCB

Temperature range $-40\text{ }^{\circ}\text{C}$ to $+150\text{ }^{\circ}\text{C}$

Applications

Automotive, white goods, ventilation, heating and energy generation, medical and industrial equipment

Specification

DIN EN 60751

Tolerance class

Class F 0.3
Group selection 0.2 K

Nominal resistances

100 Ω , 500 Ω and 1000 Ω at $0\text{ }^{\circ}\text{C}$

Temperature coefficient

3850 ppm/K

Long-term stability

< 0.1 K after 1000 h at $+150\text{ }^{\circ}\text{C}$ (energized):
Pt 100: 1.0 mA; Pt 500: 0.7 mA; Pt 1000: 0.3 mA)

Measuring current

100 Ω :
0.3 to 1.0 mA

500 Ω :
0.1 to 0.7 mA

1000 Ω :
0.1 to 0.3 mA
(self-heating has to be considered)

Track resistance

Meander: 0,06 Ω
PCB 1325.4: 0.07 Ω

Thermal fatigue resistance

≤ 0.1 K after 1000 changes $0\text{ }^{\circ}\text{C}/+150\text{ }^{\circ}\text{C}$ in air

Connection technology

Cu connection pad with chem. Sn surface

Connection technology

Chip is soldered lead-free
Connection pads are ready for lead-free soldering

Self-heating

0.15 K/mW in ice water

Response time

With SMD 0805
Water ($v = 0.4$ m/s):
 $t_{0.5} = 0.05$ sec; $t_{0.9} = 0.1$ sec
Air ($v = 2$ m/s):
 $t_{0.5} = 1.5$ sec; $t_{0.9} = 5$ sec

Processing

Suitable for wave soldering and soft soldering

Note

Other tolerances and resistance values are available on request.

This platinum temperature sensor on a printed circuit board has been specially designed for use in calorimetry. When designing these sensors, the stringent requirements of this sector with regard to precision, long-term stability, cost minimization as well as the option for fully automatic further processing were of prime concern. The temperature sensor in an SMD model forms the active measurement element on a PCB. The chip is connected with the terminal faces via meandering circuit board conductors in order to reduce heat dissipation and to prevent corruption of the measurement results. Prepared as a cable probe, it is suitable for a wide range of applications within a temperature range of $-40\text{ }^{\circ}\text{C}$ to $+150\text{ }^{\circ}\text{C}$.

Contact us!

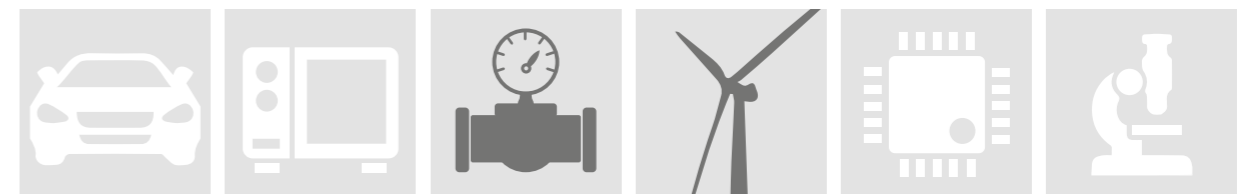
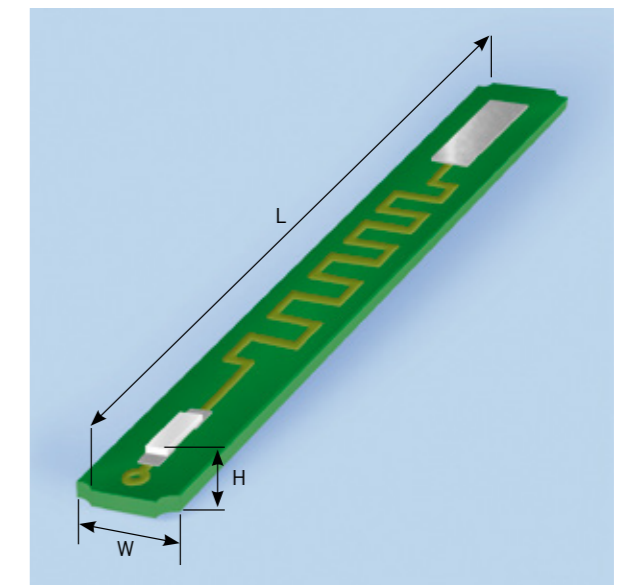

Tolerance class F 0.3 over the temperature range -40 °C to +150 °C

Type	Design	Nominal resistance	Order number Blister reel	Dimensions in mm			Self-heating	Response time in seconds	
				L	W	H	Assembled in VA tube d=5.2 mm Ice water 0 °C in K/mW	Assembled in VA tube d=5.2 mm Air: v = 2 m/s t _{0,5}	t _{0,9}
PCB	2225	Pt 100	30201075	22	2.5	0.9	0.2	3	8
PCB	2225	Pt 1000	30201063	22	2.5	0.9	0.2	3	8
PCB	2240	Pt 500	30201069	22	4.0	0.9	0.2	3	8
PCB	2240	Pt 1000	30201067	22	4.0	0.9	0.2	3	8
PCB	1325.4	Pt 500	30201107	13	2.5	1.0	0.2	3	8
PCB	1325.4	Pt 1000	30201106	13	2.5	1.0	0.2	3	8

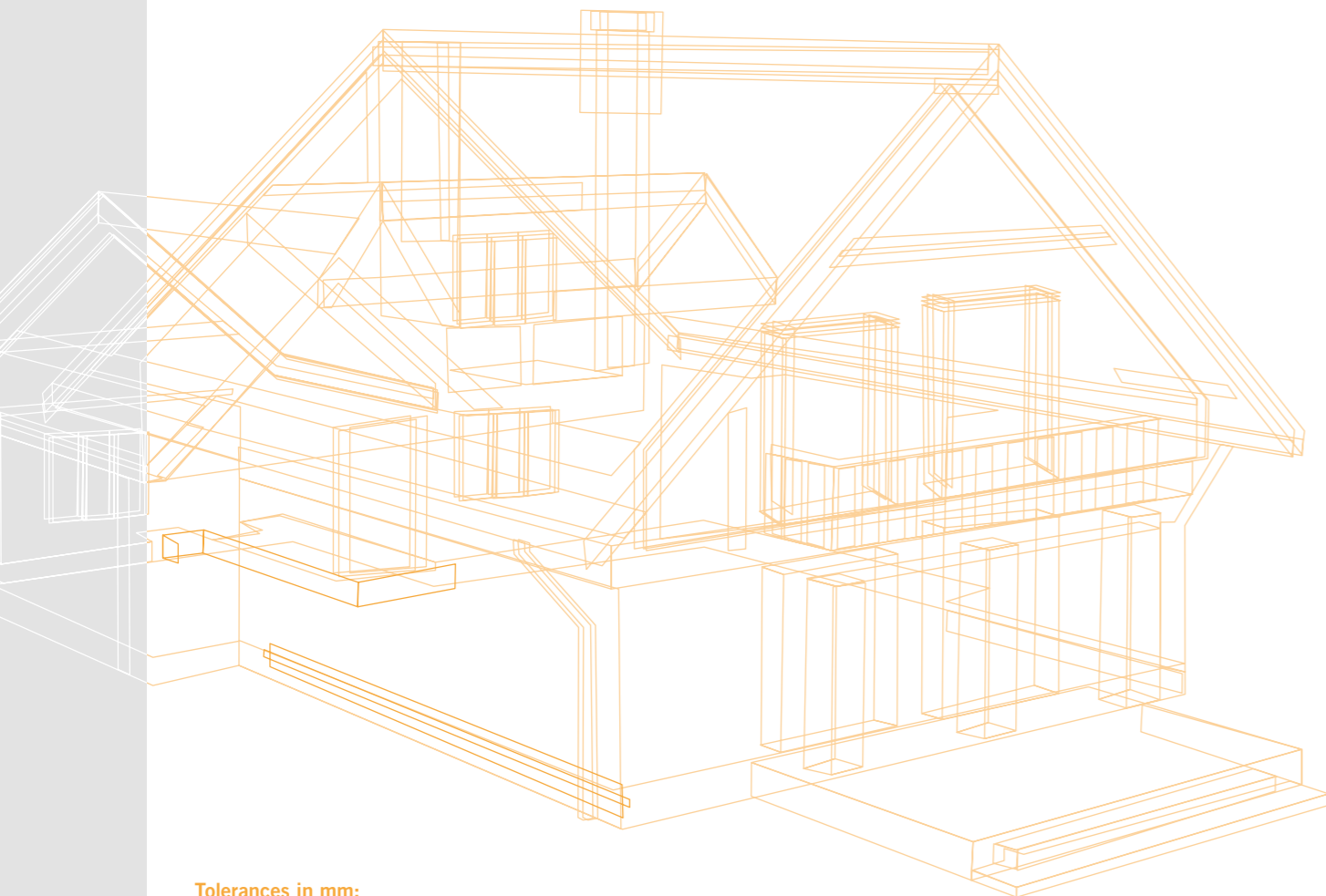

Tolerances in mm:
W: -0.2 • L: + 2.2/-0.2

Platinum Temperature Heater H 540 S

Temperature range -25 °C to +800 °C,
short-term to +850 °C

Applications

Precise heating of fluids,
gases and solids

Specification and tolerance range

Characteristic based on
DIN EN 60751
Tolerance: +/- 0,5 Ω
at 0 °C

Nominal resistance

12 Ω at 0 °C

Temperature coefficient

3850 ppm/K

Lead wire

Pt-wire, Ø 0,25 mm,
6 mm

Connection technology

Suitable for welding and
brazing

Long-term stability

Max. R₀-drift +/- 0,5 Ω
after 1000 h
at +700 °C, 3 W
after 10000 cycles
40 s on/off
(room temperature
up to +700 °C)

Heating current

Max. 1000 mA

Heating voltage

Max. 24 V (consider
temperature-dependent
resistance)

Maximum temperature

+800 °C, short-term
up to +850 °C (1 hour)

Heating time

≥ 12 seconds from
+25 °C to +700 °C
Test conditions:
Not installed in still air at
room temperature

Supply range

H 540 S offers a great temperature range, making it
deployable for many applications. Customized designs
can be considered to suit very large requirements.

Contact us!

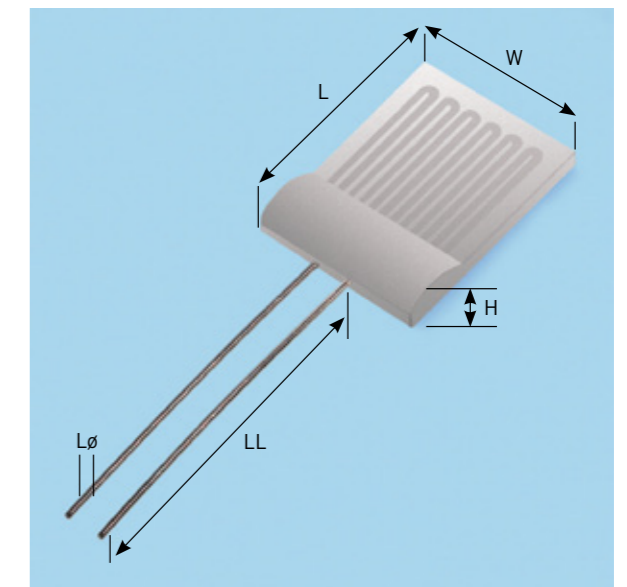

Heater H 540 S: Temperature range -25 °C to +800 °C

Type	Design	Nominal resistance	Order number Plastic bag	Dimensions in mm				
				L	W	H	LL	LØ
H	540 S	Pt12	5084080	5.2	3.9	1	6	0.25

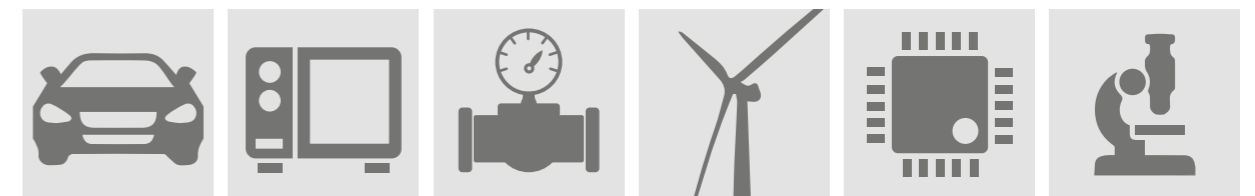

Solutions and Sensor Modules for Customized Applications



The range of applications using the Pt thin-film technology extends well beyond the manufacture of classic Pt temperature sensors.

The multi-functionality concept utilizing platinum thin-film technology has been applied to create sensor modules. The designs range from straightforward single-chip sensor/heater combinations, to complex multiple feature chips containing sensors, heaters, electrodes, and other components. For our customers, there is also an option to apply sensitive layers on the electrode: Through the use of metal oxides, for example, multi-sensor platforms become gas sensors capable of measuring concentrations of oxygen, carbon monoxide, nitrogen or methane, down to the ppm range.

In addition to applications in gas and humidity measurement, platform chips customized for aqueous media analysis in biomedical technology applications, and other similar applications, are possible. YAGEO Nexensos, a specialist and leader in platinum thin-film technology, is your first contact and development partner in the area of multi-sensor platforms with custom designed Pt structures for sensors, heaters or electrodes in mono- or multi-layer design.

Contact us!

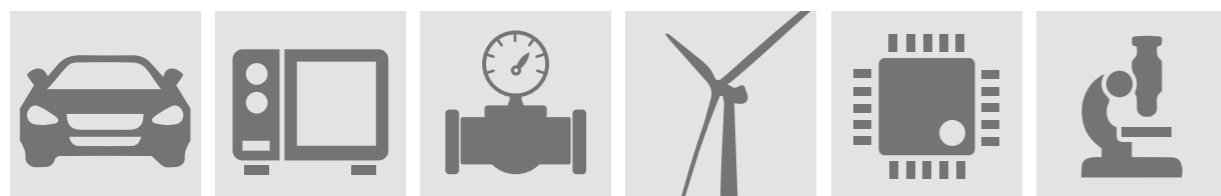

YAGEO Nexensos GmbH
Reinhard-Heraeus-Ring 23
63801 Kleinostheim, Germany
www.yageo-nexensos.com

YAGEO Nexensos worldwide
Nexensos.germany@yageo.com
Nexensos.china@yageo.com
Nexensos.america@yageo.com
Nexensos.japan@yageo.com
Nexensos.korea@yageo.com

